



RDBT3R5-FP143-553NC-RLC

1310/1550nm LC BOSA Module

1. Description

RDBT3R5-FP143-553NC-RLC Bi-Directional product is designed for P2P digital communication applications. It contains a 1310nm InGaAsP/InP MQW-FP laser diode, a 1550nm InGaAs photodetector, an edge filter(1310nm transmit/1550nm reflect) to separate 1310nm output light and 1550nm input light, coupling using single fiber with LC receptacle. The FP laser diode has included monitoring PD and ball lens cap. The product is designed for up to 1.25Gbps transmission in optical communication systems.

2. Features

- 2.1 Bi-Direction package with single fiber and LC/PC connector
- 2.2 1310nm FP laser diode as transmitter up to 1.25Gbps data rate
- 2.3 1550nm InGaAs PIN+TIA as receiver up to 1.25Gbps data rate
- 2.4 High Isolation, Return Loss and excellent Responsivity
- 2.5 Commercial-grade applications
- 2.6 Excellent performance and reliability

3. Applications

- 3.1 SONET/SDH transmission systems
- 3.2 P2P transmission systems

4. Absolute Maximum Ratings

Parameter	Symbol	Min.	Max.	Unit	Comments
Operating Temperature	T_{op}	0	70	°C	
Storage Temperature	T_{stg}	-40	85	°C	
Storage and Operating Humidity	-	5	85	%	
LD Forward Current(Transmitter)	I_{LD}	-	120	mA	
LD Reverse Voltage (Transmitter)	V_{RL}	-	2	V	
PD Forward Current(Transmitter)	I_{FD}	-	2	mA	
PD Reverse Voltage(Transmitter)	V_{RD}	-	15	V	
Power Supply Voltage(Receiver)	V_{CC}	-	+4	V	
Lead Soldering Temperature/Time	T_{slid}/t	-	260/10	°C/s	Temperature/Time



5. Optical and Electrical Characteristics($T_c=25 \pm 3 \text{ }^\circ\text{C}$, unless otherwise specified)

Transmitter						
Parameter	Symbol	Min.	Typ.	Max.	Unit	Condition
Output Power	Pf	0.3	-	0.8	mW	CW, I _{op} =I _{th} +20mA
Threshold Current	I _{th}	-	9	15	mA	CW
Forward Voltage	V _f	-	-	1.5	V	CW, I _{op} =I _{th} +20mA
Center Wavelength	λ_c	1290	1310	1330	nm	CW, I _{op} =I _{th} +20mA
Spectrum Width	$\Delta \lambda$	-	-	3.0	nm	CW, I _{op} =I _{th} +20mA
Tracking Error (Note 1)	TE	-1.0	-	1.0	dB	T _c =0~70 °C
Monitor Current	I _m	100	-	1000	uA	CW, I _{op} =I _{th} +20mA, V _R =1V
Monitor Dark Current	I _D	-	-	0.2	uA	V _R =10V
Data Rate	Br	1.25	-	-	Gbps	CW, I _{op} =I _{th} +20mA, λ =1310nm
Note1: I _m hold(@I _{th} +20mA, 25 °C), TE = 10log(P _{Tc} / P ₂₅), T _c =0~70 °C, APC						
Receiver						
Parameter	Symbol	Min.	Typ.	Max.	Unit	Condition
Operating Wavelength	λ_{op}	1480	1550	1580	nm	CW
Supply Voltage	V _{cc}	3.0	3.3	3.6	V	
Supply Current	I _{cc}	-	28	35	mA	
Resposivity	R	0.8	-	-	A/W	Pin=-30dBm, λ =1550nm
Optical Sensitivity	Sen	-	-27	-24	dBm	AC, RL=50 Ω ,NRZ 1.25Gbps, PRBR=2 ²³ -1
Saturation Power	P _s	-3	0	-	dBm	BER=10 ⁻¹⁰ , λ =1550nm
-3dB Bandwidth	BW	750	-	-	MHz	AC, RL=50 Ω , Pin=-20dBm, λ =1550nm
Dark Current	I _d	-	-	5	nA	
Output Impedance	R _o	-	50	-	Ω	
Data Rate	Br	1.25	-	-	Gbps	CW, λ =1550nm



6. Package Information & Pin Definitions

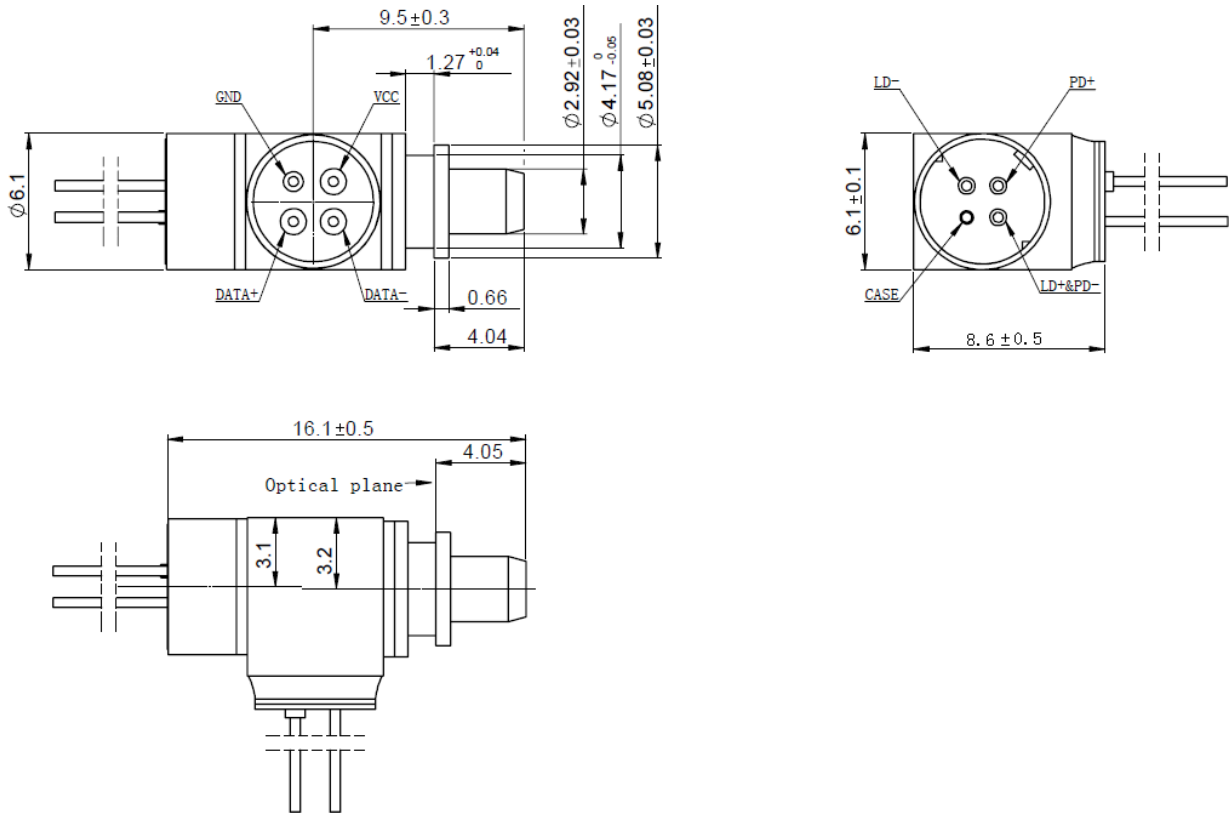



7. Ordering Information

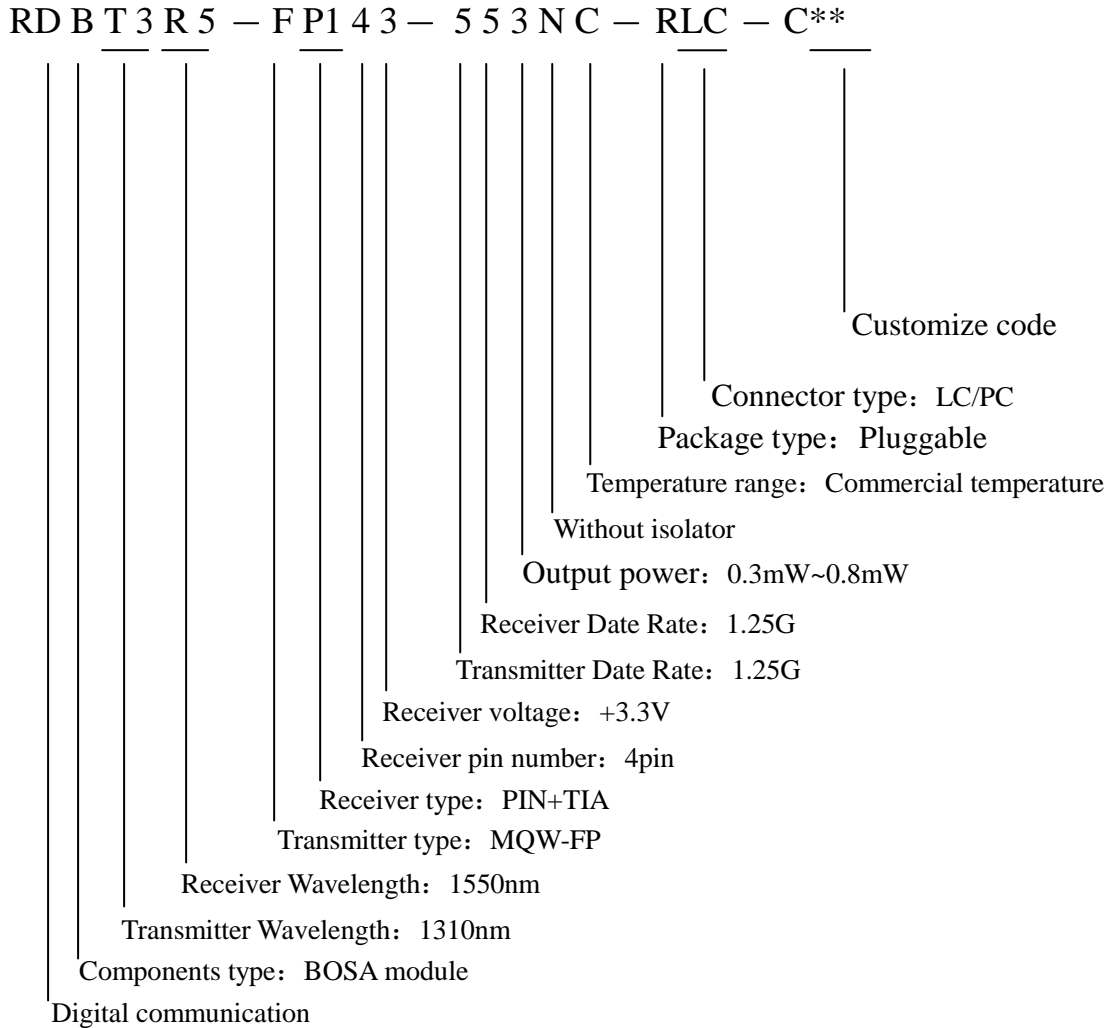

8. Warning

- 8.1 Radiation emitted by laser devices can be dangerous to the eyes. Avoid eye or skin exposure to direct or scattered radiation.
- 8.2 Handled in the same manner as ordinary semiconductor devices to prevent the electro-static damages. For safekeeping and carrying, the modules should be packaged with ESD proof material. To assemble the modules on PCB, the workbench, the soldering iron and the human body should be grounded.
- 8.3 Pay special attention to the atmosphere condition because the dew on the module may cause some electronic damages.
- 8.4 Under such a strong vibration environment as in automobile, the performance and reliability are not guaranteed.